

Maxiflow Series

Spin-on Filters

Max. 360 l/min - 10 bar



Designed for both suction and return application

Spin-on filters

The Maxiflow Series full flow filters for suction or return are designed to provide quality protection for hydraulic or lubrication systems.

Rated at a maximum pressure of 10 bar at 360 l/min, Maxiflow filters cover a wide range of mobile and industrial applications.



Contact Information:

Parker Hannifin
Hydraulic Filter Division Europe

European Product Information Centre
Freephone: 00800 27 27 5374
(from AT, BE, CH, CZ, DE, EE, ES, FI, FR, IE, IT, PT, SE, SK, UK)
filtrationinfo@parker.com

www.parker.com/hfde

Product Features:

- Maxiflow full flow filters for suction or return applications.
- Available with optional indicators.
- Maximum pressure 10 bar. Maximum flow 360 l/min.
- High quality filter medium.



Maxiflow Series

Spin-on Filters

Max. 360 l/min - 10 bar

Features & Benefits

Features	Advantages	Benefits
High quality paint for canisters	Long term protection against corrosion	Better protection against environmental influences
Spin-on filters available for suction and return line filtration	Flexible product offering	Standardisation of components
High quality filter medium	Filter medium suitable for fatigue load due to high frequent flow fluctuation	Extended element life time

Typical Applications

- Telescopic handlers
- Refuse vehicles
- Road sweepers
- Compactors
- Industrial power units
- Grass cutters
- Press brakes



MXA 1 Series



MXA 2 Series



MXA 3 Series

The Parker Filtration Maxiflow Full Flow Filters for Suction or Return.

Maxiflow filters are ideally suited to full flow and bypass circuit installations where the need for high quality filter media is recommended for effective protection of system components, improving system productivity and profitability.

Optional indicators provide direct information as to when the spin-on canisters require replacement.

Specification

Maximum working pressure:	MXA Series 10 bar
Filter head material:	Aluminium alloy
Filter bowl material:	Steel
Seal material:	Nitrile
Operating temperature range:	-30°C to +100°C
Bypass:	Return line 1.7 bar Suction line 0.2 bar No bypass option
Fluids:	Mineral oils
Element media:	Microglass III media Cellulose media

Installation Details

MXA 1 Series

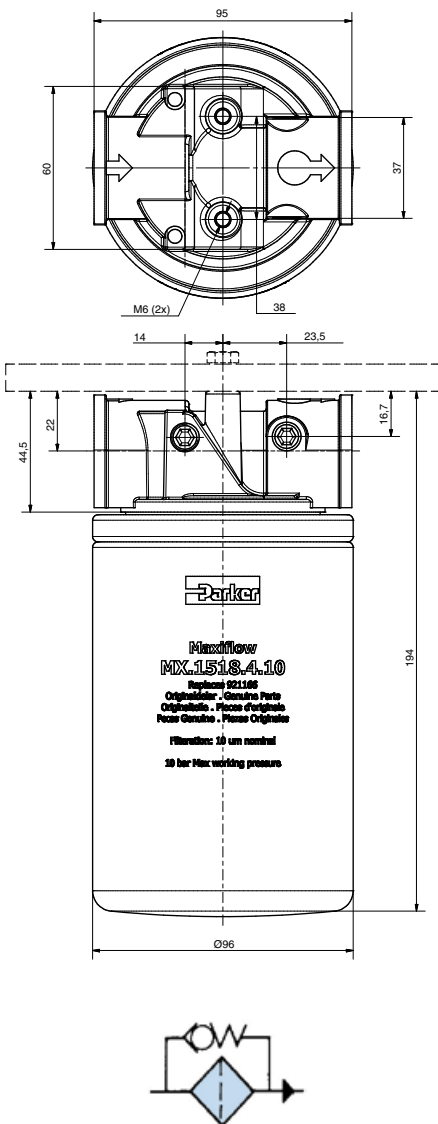

MXA 2 Series

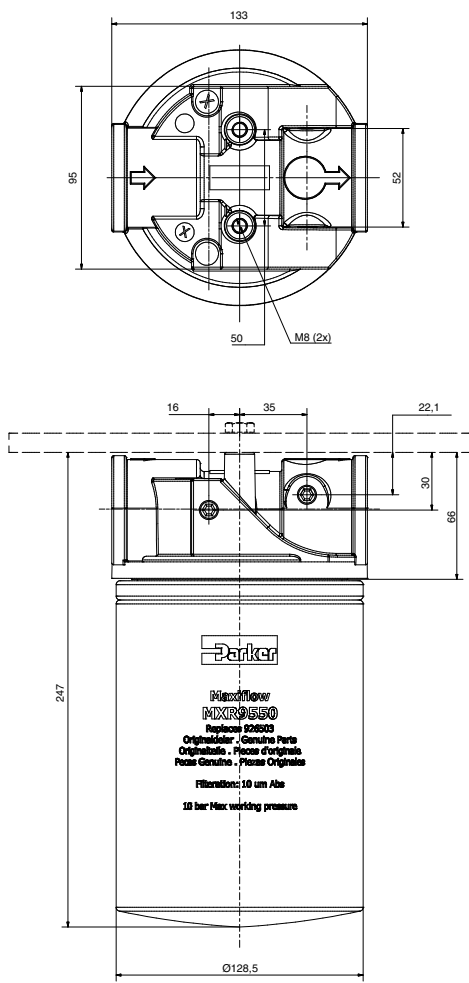

MXA 3 Series

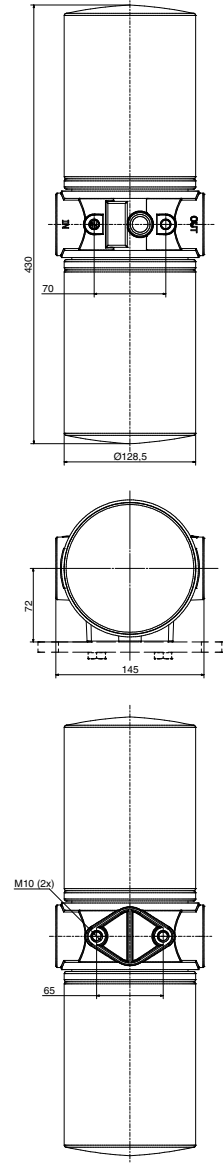

Parker Hannifin
 Hydraulic Filter Division Europe
 FDHB500UK/Maxiflow



Maxiflow Series

Pressure Drop Curves

The recommended level of the initial pressure drop for low pressure filters is max 0.5 bar.

If the medium used has a viscosity different from 30cSt, pressure drop over the filter can be estimated as follows:

$$\Delta p = (\Delta p_{30} \times \text{viscosity of medium used}) / 30\text{cSt}$$

Maxiflow MXA 1 Series

Filter Housing

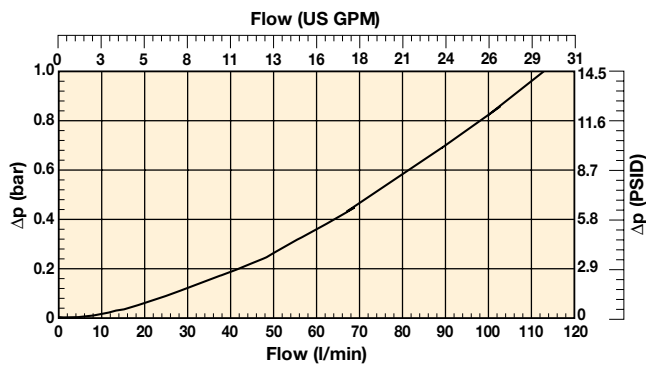

Filter Element

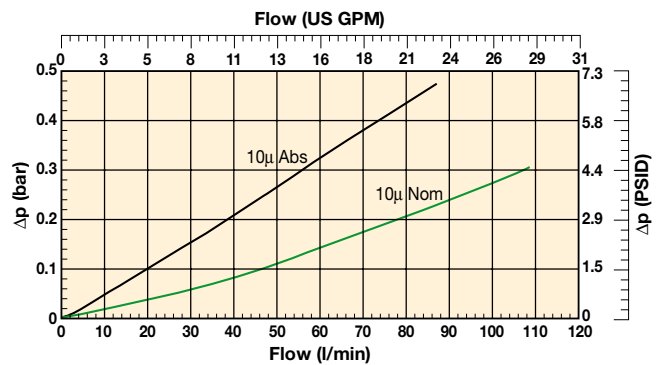

Maxiflow MXA 2 Series

Filter Housing

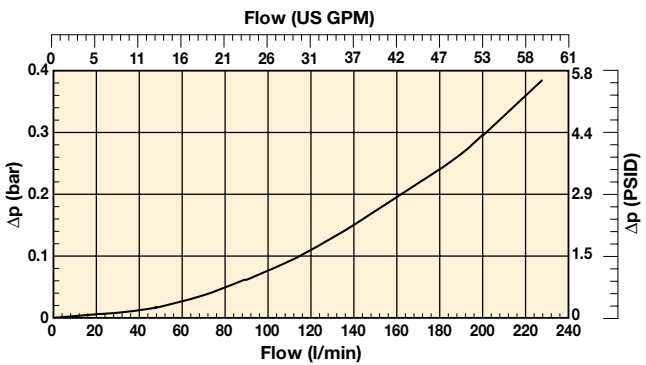

Filter Element

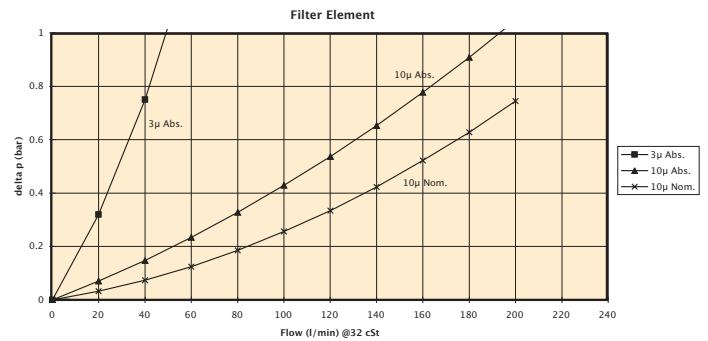

Maxiflow MXA 3 Series

Filter Housing

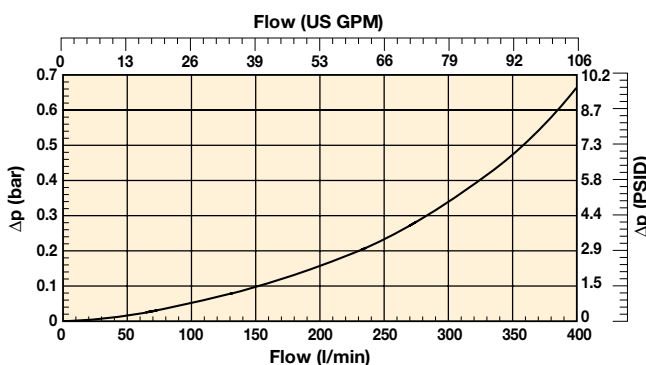

Filter Element

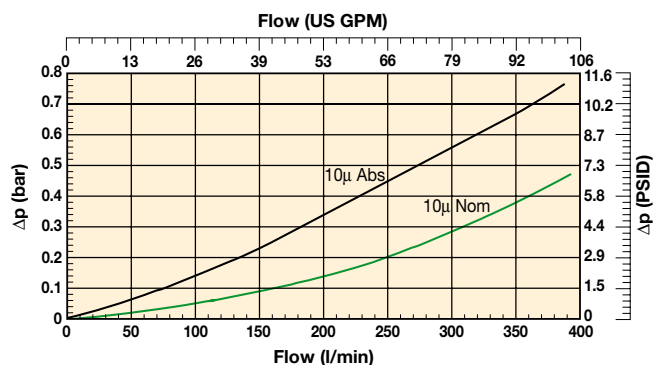

Note: All above data is calculated at 30cSt Rel density 0.856.



Indicator Specifications

Option

Visual Pressure Indicator
Code G2

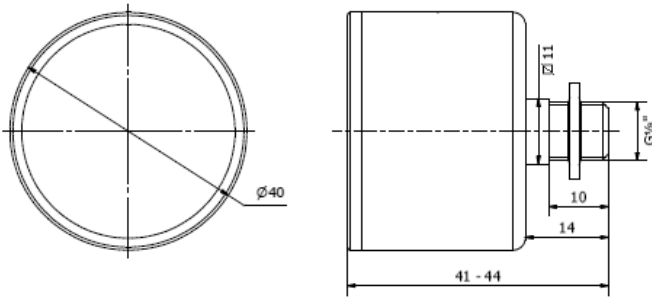

Visual indicator	
Thread connection	G1/8
Code	FMUG2EBPG02L

Option

Indicator PS NO/NC Pressure Switch
Code S2/S3

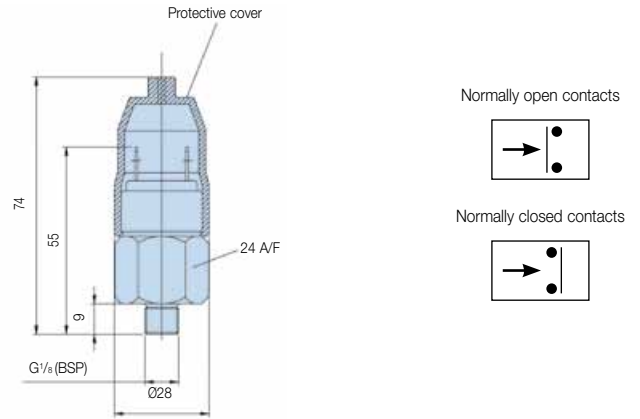

Specifications	
Elec.rating	42V / 2A
Thread connection	G1/8
Elec.connection	AMP terminal 6.3x0.8
Protection	IP65 (terminal IP00)
Switch type	NO or NC
Code	FMUS2EBMG02L (NO switch) FMUS3EBMG02L (NC switch)

Ordering Information

Box 1

Housing type	Code
MXA1	MXA1
MXA2	MXA2
MXA3 Double element version	MXA3

Box 2

Element Length	Dimensions	Thread Spin-on can	Code
Short (MXA 1 only)	D=97.0 L=58.5	G3/4"	On request
Size 1 (MXA 1 only)	D=97.0 L=145	G3/4"	2
Size 2 (Not for MXA1)	D=128.0 L=180	G1 1/4"	3
Ext'd Size 2 (Not for MXA1)	D=128.0 L=226	G1 1/4"	On request

Box 3

Filter Media	Code
10 micron Microglass III Abs.	10Q
10 micron (nom) Cellulose	10C
3 micron Abs. (MXA2 + 3 only)	03Q

Box 4

Seal Material	Code
Nitrile	B

Box 5

Indicator	Code
Plugged port	P
Pressure Switch 42V, 1.2 bar setting, NO	S2
Pressure Switch 42V, 1.2 bar setting, NC	S3
Pressure Gauge, setting 1.2 bar	G2

Box 6

Bypass Valve	Code
1.7 bar	G
Blocked Bypass	X
0.2 bar Suction	On request

Box 7

Ports	Code
G3/4" (MXA1 only)	G12
G1 1/4" (MXA2 only)	G20
G1 1/2" (MXA3 only)	G24

Box 8

Housing type	Code
Standard	1